

For 2012 the standard attenuator may require the addition of a diagonal tube in the plane of the front bulkhead that connects two nodes. An optional configuration is an "X" brace that connects all four corners of the front bulkhead.

Fore more information see the following pages.

Note: Attenuators purchased from BSCI will not include optional radii on edges or mounting holes. Mounting holes shown are for reference only - attachment is up to the team to determine.

PROPRIETARY AND CONFIDENTIAL
THE INFORMATION CONTAINED IN THIS DRAWING IS COPYRIGHT 2011 BY SAE INTERNATIONAL.

Updated	11/19/11	UNLESS OTHERWISE SPECIFIED:	NAME	DATE
		DIMENSIONS ARE IN INCHES	DRAWN	WBR 3/14/11
		TOLERANCES:	CHECKED	
		FRACTIONAL ±0.015	ENG APPR.	
		ANGULAR: MACH ± 0.3	MFG APPR.	
		TWO PLACE DECIMAL ± 0.010	Q.A.	
		THREE PLACE DECIMAL ± 0.003	The Type 12 attenuator is unchanged from the 11 but for 2012 the additional front bulkhead diagonal tube is required, see note.	
		INTERPRET GEOMETRIC TOLERANCING PER:		
		MATERIAL		
		Impax 700 Foam		
		FINISH		
NEXT ASSY	USED ON			
APPLICATION		DO NOT SCALE DRAWING		

TITLE:		
FSAE Impact Attenuator Type 11		
SIZE	DWG. NO.	REV
A	FSAE-IA-12	1
SCALE: 1:8	WEIGHT:	SHEET 1 OF 1

IMPACT ATTENUATOR

- The 2012 (Type 12) Attenuator is geometrically similar to the 2011 (Type 11)
- For 2012 attenuators purchased in either 2011 or 2012 may be used since they are identical
- There is a new requirement for 2012 that a diagonal tube must be included in the front bulkhead unless the size of the front bulkhead is within 25mm (1 inch) on each side of the standard attenuator – see next page

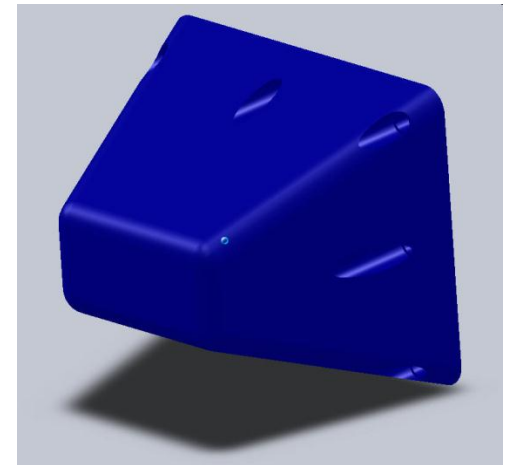

Standard IA TYPE12

IMPACT ATTENUATOR

- The standard attenuator may be mounted in either orientation
- If any dimensions exceeds the values given below an additional diagonal must be included in the front bulkhead – see next page
- The diagonal tube is required for front bulkheads larger than that shown below because the anti-intrusion plate would deflect more than allowed by B3.21.9

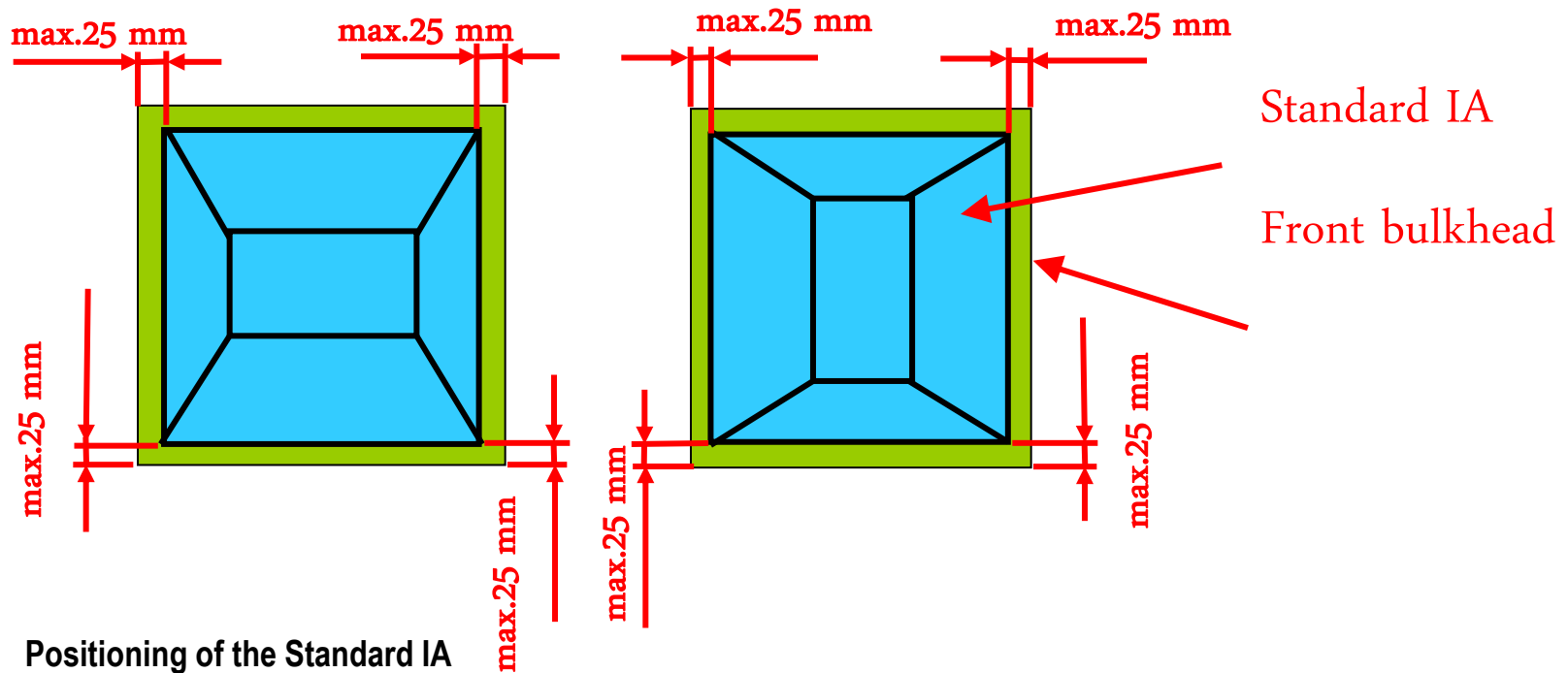

IMPACT ATTENUATOR

- If the front bulkhead exceeds the 25mm (1 inch) requirement on any side than at least on additional diagonal tube must be included in the front bulkhead
- The tube(s) must meet the requirement of 3.3.1 Front Bulkhead Tubing or equivalent
 - Round 1.0 inch (25.4 mm) x 0.049 inch (1.25 mm)
 - See Rule 3.3.1 for other options

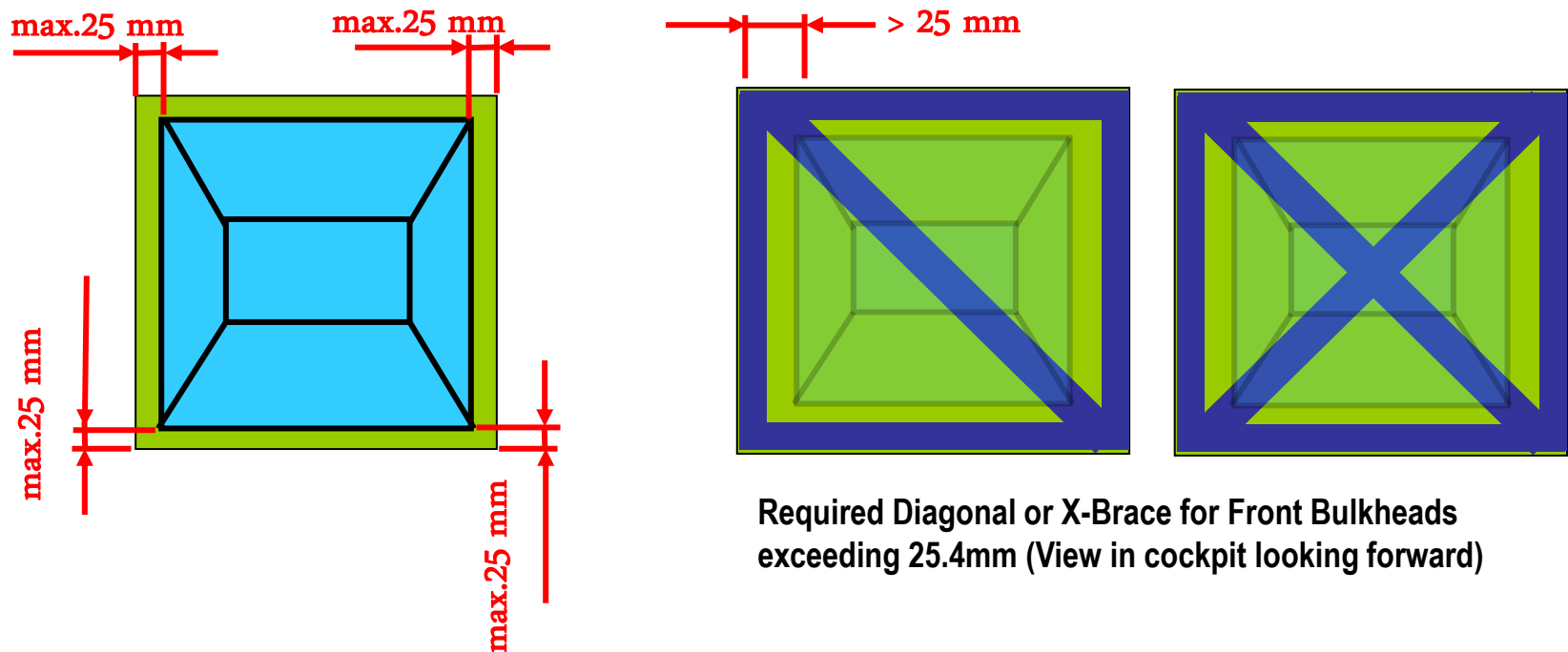

IMPACT ATTENUATOR

- No modifications to the attenuator geometry are permitted besides the fillets/radii included on the drawing

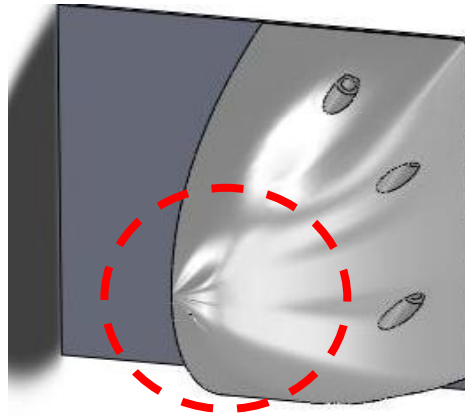

NOT PERMITTED: changed design or dimensions for Standard IA TYPE12

IMPACT ATTENUATOR

- The following details should be submitted with the impact attenuator data submission

Description of:

- Design of IA and positioning to AIP (dimensions)
- Dimension of the front bulkhead
- Design of AIP (material, thickness, dimensions)
- Attachment method of the IA to the AIP
- Attachment method of the AIP to the front bulkhead
- Receipt of the material, a packing slip or letter of donation
- Pictures of attachment to the car